

Prof. Radhakrishna Rao Foundation
announces

A Lecture Series
in Analog VLSI

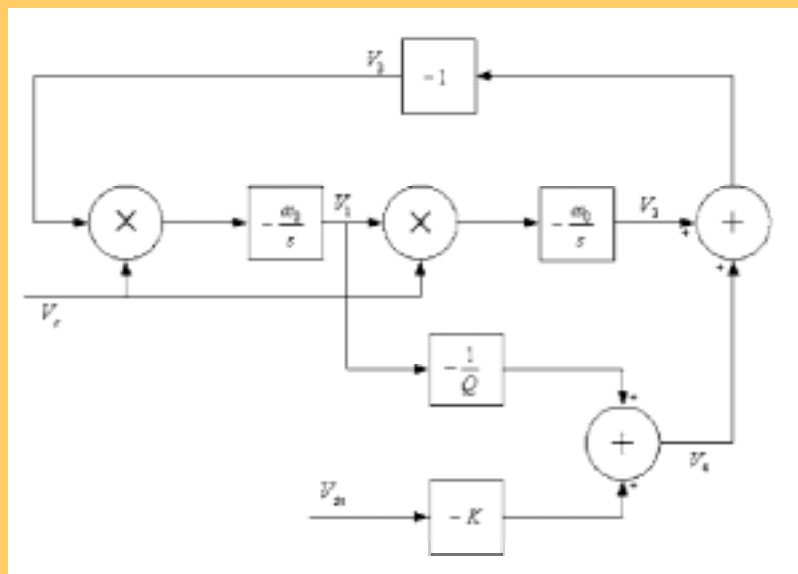

June 4-15, 2007



Thiagarajar College of Engineering
Madurai

Anchored by





 **TEXAS INSTRUMENTS**

www.india.ti.com

Advance Program Schedule

The schedule on all days will include 3 hrs of tutorial lectures in the morning and 4 hours of lab instruction in the afternoon. Participants must report to the registration desk on June 4 at 8.30 AM. They are requested to make their travel arrangements accordingly. The morning tutorial session begins at 9.30 AM and concludes at 1.00 PM on all days. The afternoon lab session begins at 2.00 PM and concludes at 6.00 PM on all days. There will be a lunch break (1.00 PM – 2.00 PM) and two coffee breaks (10.30 AM – 11.00 AM and 3.30 PM – 4.00 PM) on all days. On the first day, a brief inauguration ceremony is planned. Certificates of participation will be distributed in the valedictory function planned on the last day. Participants must ensure that they are present to collect their certificates. Course notes/handouts will be made available on a weekly basis. A test will be conducted at the end of the course.

Speakers at the Radhakrishna Rao Lecture Series in TCE Madurai

	<p>Prof. K. Radhakrishna Rao obtained a B.Tech in Electrical Engineering from IIT Madras in 1966, and a Ph.D. in electrical engineering from Indian Institute of Technology, Kanpur, in 1971. From 1971-2006, he served on the board of faculty at the Department of Electrical Engineering, IIT Madras. He supervised a number of theses in the areas of Analog Integrated Circuit Design and active filters. After his retirement from IIT Madras, Prof. Rao joined Texas Instruments, Bangalore, India as a Distinguished Member of Technical Staff (Emeritus).</p>
	<p>Shanthi Pavan obtained the B.Tech degree in Electronics and Communication Engg from the Indian Institute of Technology, Madras in 1995 and the M.S and Sc.D degrees from Columbia University, New York in 1997 and 1999 respectively. From 1997 to 2000, he was with Texas Instruments in Warren, New Jersey, where he worked on high speed analog filters and data converters. From 2000 to June 2002, he worked on microwave ICs for data communication at Bigbear Networks in Sunnyvale, California. Since July 2002, he has been with the Electrical Engineering Department of the Indian Institute of Technology-Madras, where he is an Assistant Professor. His research interests are in the areas of high speed analog circuit design and signal processing.</p>
	<p>Nagendra Krishnapura is with the Department of Electrical Engineering of the Indian Institute of Technology, Madras since 2005. He works in the area of mixed signal circuits and signal processing. He graduated with a Ph.D. from Columbia University, New York in Oct. 2000. He worked at the Columbia Integrated Systems Laboratory under the guidance of Prof. Yannis Tsvividis in the area of nonlinear analog signal processing for low power integrated circuits. He obtained his B. Tech. degree in electronics and communications engineering from the Indian Institute of Technology, Madras, in 1996. Between 2000 and 2005, he worked as a senior design engineer at Celight, Inc. and Multilink (later Vitesse Semiconductor) where he designed integrated circuits for high speed communications.</p>
	<p>Sundararajan Krishnan (PK) received his B. Tech in Electrical Engineering from the Indian Institute of Technology, Madras in 1998 and the M. S. and Ph. D. in Electrical and Computer Engineering from the University of California, Santa Barbara in 1999 and 2002, respectively. He joined Texas Instruments in 2002 where he was involved in the design of power amplifier for WLAN applications, and analog system engineering for DSL systems. Since its inception, he has been with Cosmic Circuits, a Bangalore-based start-up focusing on the design of analog and mixed-signal circuits, and designs high-speed analog-to-digital converters.</p>
	<p>Venu Gopinathan obtained his B.Tech in Electronics from IIT Madras, Chennai, India in 1986 and MS and PhD from Columbia University in 1987 and 1990 respectively. He worked at Texas Instruments, Bell Labs, Lucent technologies, and Broadcom. He presently leads the Wireless Systems Group in TI India.</p>

